

Multi-Resolution Analysis Based MRI Image Quality Analysis using DT-CWT Based Preprocessing Techniques

M. Vinay Kumar¹, Sri P. MadhuKiran²

¹PG Scholar, Department of E.C.E, Sree Chaitanya College of Engineering, Karimnagar, Telengana, India

²Assistant professor, Department of E.C.E, Sree Chaitanya College of Engineering, Karimnagar, Telengana, India

E-mail- vinaykumar.mundada@gmail.com, Contact No-+91-9492204128

Abstract—The main objective of this paper is to improve the image quality by de-noising and resolution enhancement Techniques. The medical image quality parameters are mainly noise and resolution. This paper targets the average, median and wiener filters for image denoising and Discrete Wavelet Transform (DWT) and Dual tree Complex Wavelet Transform (DT-CWT) techniques for resolution enhancement, and it shows the results comparisons between DWT and DT-CWT. The performance of these techniques is evaluated using Peak Signal to Noise Ratio (PSNR).

Keywords—Image preprocessing, salt and pepper noise, Discrete Wavelet Transform (DWT), Stationary Wavelet Transform (SWT), Dual Tree complex Wavelet Transform (DT-CWT), and Peak Signal to Noise Ratio (PSNR).

INTRODUCTION

Magnetic resonance imaging (MRI) is a medical imaging technique used to produce a high quality soft tissues of human body, here externally applied strong magnetic field and hydrogen atoms in 1.5 Tesla field process at 64 MHz so at that range of high frequencies tremendous noise is added to the MRI image [1]. MRI scans can be used to study the brain, spinal cord, bones, joints, breasts, the heart and blood vessels. It can also be used to look at other internal organs. MRI scans can be used to find blood clots as well. An MRI scan can be used as an extremely accurate method of disease detection throughout the body. Neurosurgeons use an MRI scan not only in defining brain anatomy but in evaluating the integrity of the spinal cord after an injury. An MRI scan can evaluate the structure of the heart. Even small amount of noise can change the image classification. The MRI noisy image can cause misclassification of Gray Matter (GM) and White Matter (WM). The gray matter is made up of neural cell bodies and white matter is a component of central nervous system [2]. So the noisy image is preprocessed using denoising and resolution enhancement. The denoising mechanism is not better performed along the edges; this drawback is modified by using of Resolution enhancement Techniques. In order to significantly accelerate the algorithm, filters are introduced to averaging filter, median filter, wiener filters for eliminate the noise in denoising mechanism. These filters are reducing the quadratic complexity of a given image. The median filter produces better denoising image in the addition of salt and pepper noise. The wiener filter performs remove the image additive noise and inverts the blurring simultaneously. After denoising mechanism the noise gets removed and edges are not good, because some missing of neighborhood pixels in the edges. This edges information is recovered by using of resolution enhancement techniques. In MRI image, the doctors are mainly concentrated at edges like tissues, tumors etc. in this project Discrete Wavelet transform (DWT), and Dual tree Complex Wavelet Transform (DT-CWT) is used for resolution enhancement. In the proposed technique, DWT (Discrete Wavelet Transform) and SWT (Stationary Wavelet Transform) high frequency sub-bands are merged and getting estimated high frequency bands they are LH, HL, and HH respectively. After applying of inverse wavelet transform, getting one resultant image. And that resultant image is processed by DT-CWT technique, getting more qualitative enhanced image. This enhanced image is more helpful for proper treatment.

DENOISING MECHANISM

MRI images are degraded by noise. So that the image is preprocessed using denoising mechanism to extract useful information. This paper concentrates the mean filter, median filter, wiener filter for image denoising & Discrete Wavelet transform (DWT) and Dual tree complex Wavelet Transform (DT-CWT) for Resolution enhancement. The block diagram of proposed as shown in below.

Salt and pepper noise

Medical images corrupted by salt-and-pepper noise (ON or OFF pixels), modeled as only two possible values they are. Salt and pepper noise May occurring white (salt) and black (pepper) pixels. For an 8 bit/pixel image, the typical intensity value for pepper noise is

close to zero and for salt noise is close to 256. The noise density term usually quantifies the number of salt and pepper noise in a picture. A complete noise density of ND in an M x N image means ND x M x N pixels contain noise .the whole noise density is

$$ND = ND1 + ND2 \quad (1)$$

Here ND1 and ND2 are salt and pepper noise densities respectively.

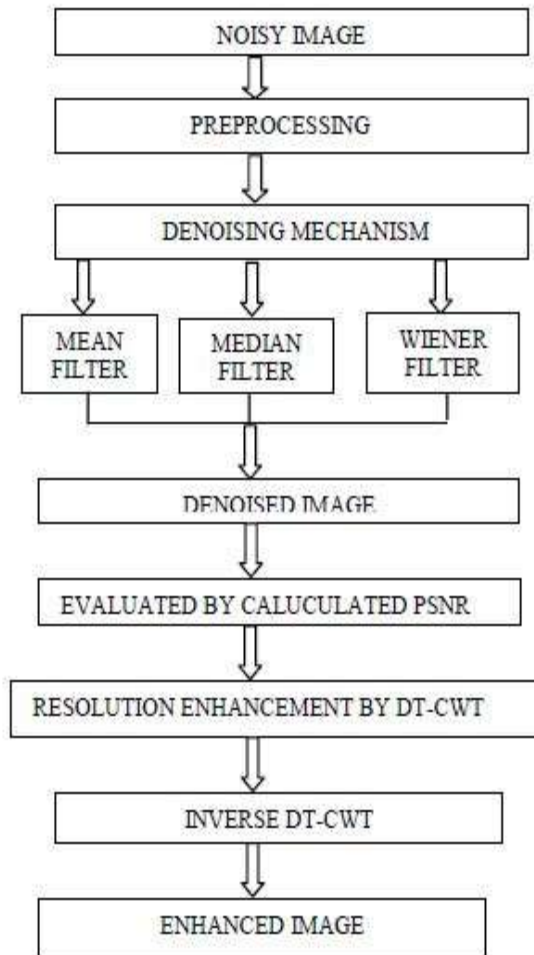

Fig.1. Overview of proposed work

Average filter

Filtering is a part of image enhancement .the Mean filter or average filter is a simplest linear filter used as smoothing image applications. Average filter is used to reduce the noise and intensity variation from one pixel to another. The average filter works by moving through the image pixel by pixel, replacing each value with the average value of neighboring pixels.

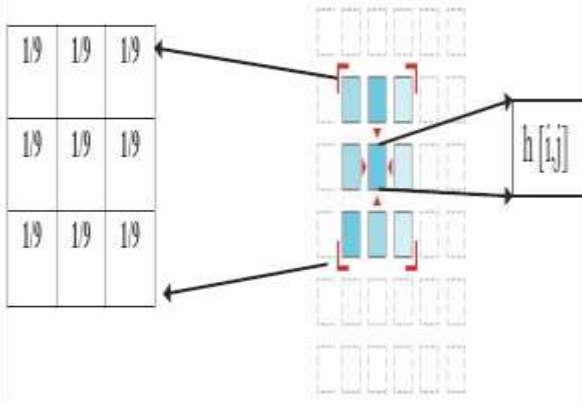

Fig.2. Functionality behind the averaging filter

$$h[i, j] = \frac{1}{M} \sum_{(k,l) \in N} f(k, l) \quad (2)$$

Where M is total number of pixels in the neighborhood N and $k, l=1, 2, \dots$. For example 3x3 neighborhood about [i,j] yields:

$$h[i, j] = \frac{1}{9} \sum_{k=i-1}^{i+1} \sum_{l=i-1}^{i+1} f(k, l) \quad (3)$$

Median Filter

Median filtering is a nonlinear operation, is used to remove the noise from given Images. It is widely used as effective noise reduction and preserving the edges. Medical images typically contain salt and pepper noise. Median filter was performed by simply applying of 3x3 window method over the image [3, 4]. The arrangement of neighbors is called the window technique. Median is calculated by first arranging all the pixel values from the Window into numerical order, and then exchanging the center pixel with median value. Note that if window has an odd number of entries, and then the median is easier to define. There is more than one possible median, for even number of entries. Fig shows the working principle of median filter

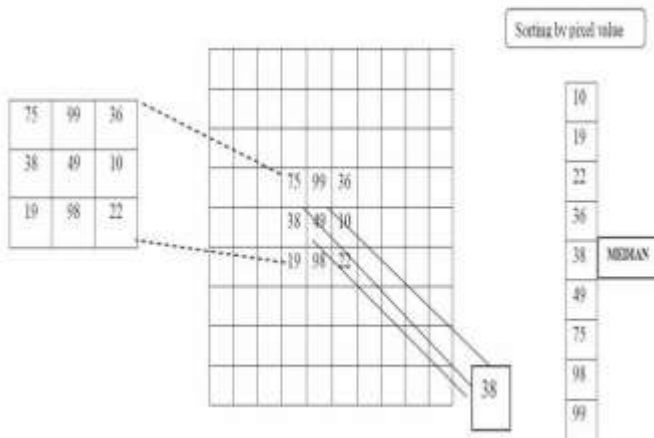

Fig3. Working principle of median filter

Wiener filter

Wiener filter is a class of linear optimum filter which involves linear estimation of desired image. It removes the additional noise in corrupted image and reverses blurring at the same time. The linear filter is most advantageous in terms of mean square error i.e.

Tradeoff between image recovery and noise suppression. This filter is effective at image de-blurring and noise suppression [4]. Wiener filter is followed by these characteristics

- a) Image and noise with known spectral characteristics
- b) Filter must be causal
- c) Performance criterion based on minimum mean square error(MMSE)

In this project wiener filter performs image denoising and quality is analyzed using peak signal to noise ratio (PSNR).

RESOLUTION ENHANCEMENT

Resolution is referred to be an important factor of a medical image processing. These Images are being preprocessed in order to obtain more enhanced resolution. Interpolation is one of the mostly referred techniques for image resolution enhancement [6]. Initially the image is preprocessed using denoising, it results noise reduction and loss of quality at the image edges. So resolution enhancement technique is used to preserve the edges and contour information of a filtered image.

Resolution is the measurement of quality of a denoised image. In order to enhance the resolution of an image an improved Discrete Wavelet Transform (DWT) and Dual Tree complex Wavelet Transform (DT-CWT) is used in this project. The performance of resolution enhancement is measured using Peak Signal to Noise Ratio (PSNR).

Discrete Wavelet Transform

Wavelets are playing an important role in many image processing applications. It is used to examine an image into the different frequency components at different resolution scales (i.e. multi-resolution). Any wavelet-based image processing approach has the following steps. Calculate the 2D-DWT of an image, alter the transform coefficients (i.e. sub-bands), and calculate the inverse transform [7, 9, 10]. In this technique interpolation based DWT is used to preserve high frequency component. DWT decomposes the input image into four sub-bands that are low-low (LL), low-high (LH), high-low (HL), and high-high (HH). After decomposition of input image, interpolation is applied on these four sub-bands. The interpolation technique is used to increase the number pixels in an image.

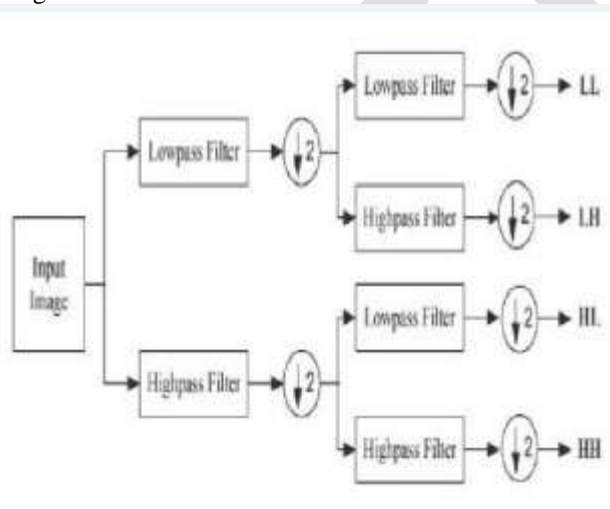

Fig.4 Block diagram of Discrete Wavelet transform

Inverse Discrete Wavelet Transform (IDWT) is a process by which components can be accumulated back into the original image to get without loss of information is called reconstruction. It reconstructs an image from the approximation and detail coefficients extracted from decomposition. The performance of denoised and enhanced image is evaluated by calculating PSNR value.

PROPOSED METHOD

In the proposed method finally Dual tree complex Wavelet Transform (DT-CWT) is used for image enhancement. In this method the interpolated DWT and SWT, high frequency sub-bands (LH, HL, and HH) are merged, and estimated new sub-bands (LH, HL, HH). After applying of inverse wavelet transform we get a resultant image [6]. Here the DWT and SWT high frequency sub-bands are same size.

In discrete wavelet transform (DWT) there is a deficiency of translation-invariance. Stationary wavelet transform (SWT) is a wavelet transform algorithm procedure designed to overcome the deficiency of translation-invariance of the discrete wavelet transform (DWT). Translation invariance is achieved by removing of down samplers and up samplers in the DWT.

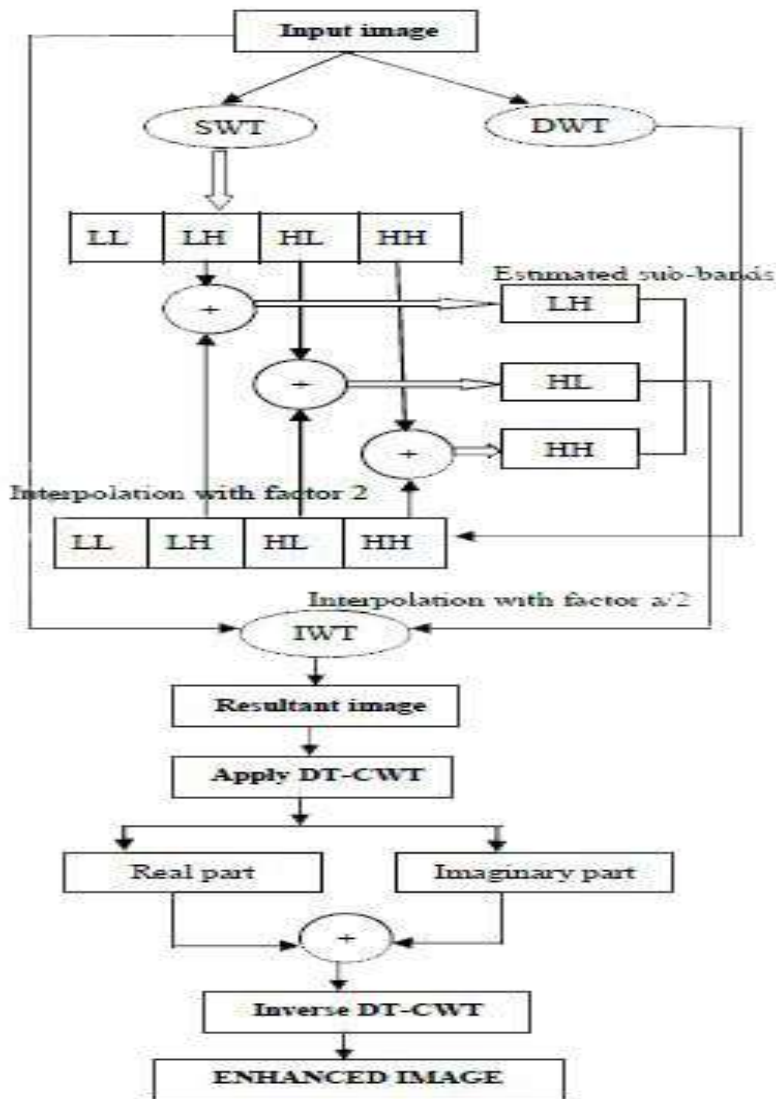

Fig.5 Block diagram of proposed work

In the proposed technique, the resultant image has applied Dual Tree Complex Wavelet Transform (DT-CWT). In this method DT-CWT image is divided into real part and imaginary part, and in this proposed technique those real & imaginary parts are merged [10]. After applying of inverse DT-CWT we get quality enhanced image. The enhanced MRI image quality is analyzed, based on peak signal to noise ratio (PSNR).

QUALITY ANALYSIS

The quality of the pre-processed images is analyzed using Peak Signal to Noise Ratio (PSNR). It is defined as the ratio between the utmost possible powers of an image to the power of corrupting noise measure of the peak error. Peak signal-to-noise ratio is measured in decibels between two images. To compute PSNR using following equation

$$PSNR = 10 \log_{10} \left(\frac{R^2}{MSE} \right) \quad (4)$$

Here Mean Square Error (MSE) is the cumulative squared error between the denoised and the original image. R is the maximum fluctuation in the input image. To compute MSE following equation

$$MSE = \frac{\sum_{M,N} [I_{1(m,n)} - I_{2(m,n)}]^2}{M * N} \quad (5)$$

Where $I_{1(m,n)}$ denotes original image, $I_{2(m,n)}$ denotes denoised image and M and N are the number of rows and columns in the input images. Logically, if the PSNR is higher it gives the better quality of the reconstructed image.

EXPERIMENTAL RESULTS

The noisy image is taken as the input image and denoising is performed using average, median and wiener filter. Fig.6 and Fig.7 shows input image and denoised images and Table.1 shows performance of denoised image.

Original Image Noisy Image

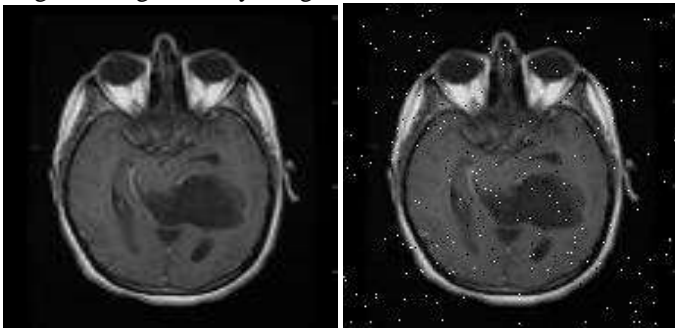

Fig.6 Original and Noisy image

Averaging Filter Median Filter Wiener Filter

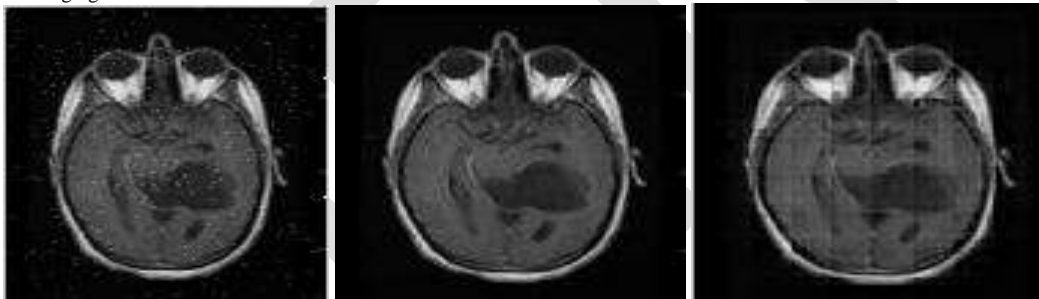

Fig.7. Denoised Images a) Averaging Filter b) Median Filtering c) Wiener Filter

TABLE I . PSNR VALUES OF THE DENOISED IMAGE

DENOISING MECHANISM	
FILTER	PSNR (dB)
a)Averaging Filter	50.5393
b)Median Filter	60.3634
c)Wiener Filter	88.0153

Original image Enhanced image using DWT

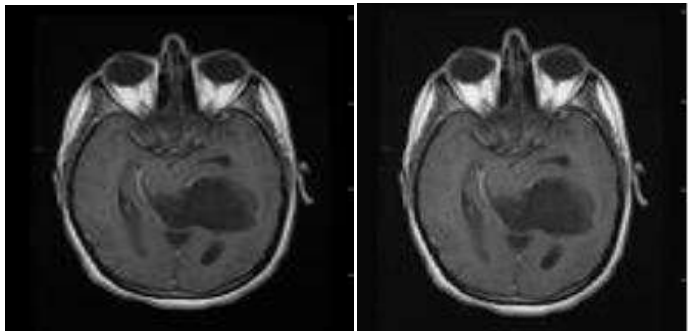

Fig.8 Original and Enhanced (DWT) image

Original image Enhanced Image Using DT-CWT

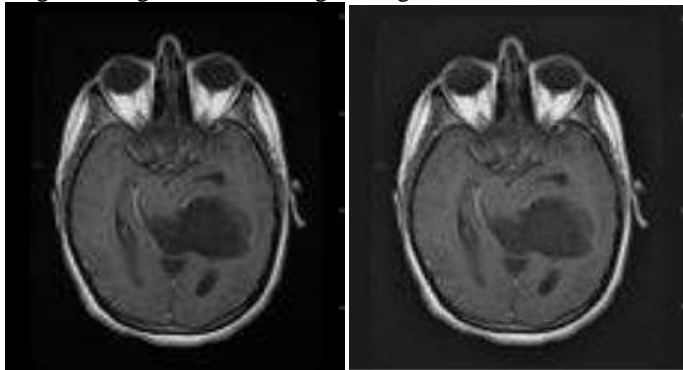

Fig.9. Original and Enhanced (DT-CWT) image

TABLE II. COMPARISON OF ENHANCED IMAGE QUALITY METRICS USING DWT AND DT-CWT TECHNIQUES

RESOLUTION ENHANCEMENT				
METHOD	QUALITY METRICS			
	PSNR(dB)	RMSE	MAE	QI
DWT	57.3492	0.121	0.076	0.385
PROPOSED METHOD	61.1933	0.049	0.037	0.676

CONCLUSION

The MRI brain image is preprocessed by denoising and resolution enhancement. In denoising, the noise gets reduced better by Wiener filtering and the resolution of an image is enhanced by Dual Tree Complex Wavelet Transform (DT-CWT). The PSNR value of Dual Tree Complex Wavelet Transform is better than, compared to Discrete Wavelet Transform (DWT). While analyzing these techniques are essential for improving the qualitative performance of an image.

REFERENCES

- [1]Alexandra Constantin, Ruzena Bajcsy, Berkeley Sarah, "Unsupervised Segmentation of Brain Tissue in Multivariate MRI," IEEE international conference on Biomedical imaging: from nano to Macro, pp. 89-92, April 2010.J.
- [2]Subhranil Koley, Aurpan Majumder, "Brain MRI Segmentation for Tumor Detection using Cohesion based Self Merging Algorithm", Communication Software and Networks –ICCSN, pp. 781-785, May 2011.

- [3]Suresh Kumar, Papendra Kumar, Manoj Gupta, Ashok Kumar Nagawat, "Performance Comparison of Median and wiener filter in image denosing", International Journal of Computer Applications , vol. 4, pp . 0975 – 8887, November 2010
- [4]Mona Mahmoudi, Guillermo Sapiro, "Fast Image and Video Denoising via Non-Local Means of similar neighborhood", IEEE Signal Processing Letters , vol. 12, pp. 839-842, 2005.D.Keren, S. Peleg and R. Brada, "Image sequence enhancement using sub-pixel displacements", Computer Vision and Pattern Recognition, Page(s): 742-746, 1988.
- [6]H. Demirel, G. Anbarjafari, "Satellite Image Resolution Enhancement Using Complex Wavelet Transform", Geoscience and Remote Sensing Letters, Volume: 7, Page(s): 123-126, 2010.
- [7]H. Demirel, G. Anbarjafari, "Discrete Wavelet Transform-Based Satellite Image Resolution Enhancement". Geoscience and Remote Sensing, Volume: 49, Page(s): 1997-2004, 2011
- [8]Liu Fang,Yang Biao, KaiGang Li, "Image Fusion Using Adaptive Dual-Tree Discrete Wavelet Packets Based on the Noise Distribution Estimation," international conference on Audio, Language and Image Processing (ICALIP), 2012 pp. 475 - 479, 2012.
- [9]Daniel G. Costa, Luiz Affonso Guedes, "A Discrete Wavelet Transform (DWT)-Based Energy-Efficient Selective Retransmission Mechanism for Wireless Image Sensor Networks," Journal of Sensor and Actuator Networks, vol. 1, pp. 3-35 , 2012.
- [10]ZhangZhong, "Investigations on Image Fusion", PhD Thesis, Universityof Lehigh, USA. May1999
- [11]Mark J. Shensa,"The Discrete Wavelet Transform: Wedding the A Trouns and Mallat Algorithms," IEEE transactions on signal processing,vol. 40, pp. 2464 - 2482, 1992