

# Design and Verification of Nine port Network Router

G. Sri Lakshmi<sup>1</sup>, A Ganga Mani<sup>2</sup>

<sup>1</sup>Assistant Professor, Department of Electronics and Communication Engineering, Pragathi Engineering College, Andhra Pradesh, India

<sup>2</sup>Research Scholar (M.Tech), Embedded Systems, Department of Electronics and Communication Engineering, Pragathi Engineering College, Andhra Pradesh, India  
Email- srilakshmi1853@gmail.com

**ABSTRACT** - The focus of this Paper is the design of Network Router and verifies the functionality of the eight port router for network on chip using verilog qualifies the Design for Synthesis and implementation. This Design consists of Registers, FSM and FIFO's. This Router design contains Eight output ports and one input port, it is packet based Protocol. Router drives the incoming packet which comes from the input port to output ports based on the address contained in the packet.. The router has an active low synchronous input resetn which resets the router. Thus the idea is borrowed from large scale multiprocessors and wide area network domain and envisions on chip routers based network. This helps to understand how router is controlling the signals from source to destination based on the header adders.

**KEYWORDS:** FIFO, FSM, Network-On-Chip, Register blocks,Router Simulation,verification plan

## INTRODUCTION

System on chip (SOC) is a complex interconnection of various functional elements. It creates communication bottleneck in the gigabit communication due to its bus based architecture. Thus there was need of system that explicit modularity and parallelism, network on chip possess many such attractive properties and solve the problem of communication bottleneck. It basically works on the idea of interconnection of cores using on chip network. The communication on network on chip is carried out by means of router, so for implementing better NOC, the router should be efficiently design. This router supports four parallel connections at the same time. It uses store and forward type of flow control and FSM Controller deterministic routing which improves the performance of router. The switching mechanism used here is packet switching which is generally used on network on chip. In packet switching the data the data transfers in the form of packets between cooperating routers and independent routing decision is taken. The store and forward flow mechanism is best because it does not reserve channels and thus does not lead to idle physical channels. The arbiter is of rotating priority scheme so that every channel once get chance to transfer its data. In this router both input and output buffering is used so that congestion can be avoided at both sides. A router is a device that forwards data packets across computer networks. Routers perform the data "traffic direction" functions on the Internet. A router is a microprocessor- controlled device that is connected to two or more data lines from different networks. When a data packet comes in on one of the lines .The router reads the address information in the packet to determine its ultimate destination. Then, using information in its routing table, it directs the packet to the next network on its journey.

## WHY WOULD I NEED A ROUTER?

For most home users, they may want to set-up a LAN (local Area Network) or WLAN (wireless LAN) and connect all computers to the Internet without having to pay a full broadband subscription service to their ISP for each computer on the network. In many instances, an ISP will allow you to use a router and connect multiple computers to a single Internet connection and pay a nominal fee for each additional computer sharing the connection. This is when home users will want to look at smaller routers, often called broadband routers that enable two or more computers to share an Internet connection. Within a business or organization, you may need to connect multiple computers to the Internet, but also want to connect multiple private networks not all routers are created equal since their job will differ slightly from network to network. Additionally, you may look at a piece of hardware and not even realize it is a router.

What defines a router is not its shape, color, size or manufacturer, but its job function of routing data packets between computers. A cable modem, which routes data between your PC and your ISP can be considered as a router. In its most basic form, a router could simply be one of two computers running the Windows 98 (or higher) operating system connected together using ICS (Internet Connection Sharing). In this scenario, the computer that is connected to the Internet is acting as the router for the second computer to obtain its Internet connection. Going a step up from ICS, we have a category of hardware routers that are used to perform the same basic task as ICS, albeit with more features and functions often called broadband or Internet connection sharing routers, these routers

allow you to share one Internet connection with multiple computers. Broadband or ICS routers will look a bit different depending on the manufacturer or brand, but wired routers are generally a small box-shaped hardware device with ports on the front or back into which you will plug each computer along with a port to plug in your broadband modem. These connection ports allow the router to do its job of routing the data packets between each of the computers and the data going to and from the Internet. These routers also support NAT (network address translation), which allows all of your computers to share a single IP address on the Internet.

## ROUTER DESIGN PRINCIPLES

Given the strict contest deadline and the short implementation window we adopted a set of design principles to spend the available time as efficiently as possible. This document provides specifications for the Router is a packet based protocol. Router drives the incoming packet which comes from the input port to output ports based on the address contained in the packet. The router is a "Network Router" has a one input port from which the packet enters. It has Eight output ports where the packet is driven out. Packet contains 3 parts. They are Header, data and frame check sequence. Packet width is 16 bits and the length of the packet can be between 1 byte to 8192 bytes. Packet header contains three fields DA and length. Destination address (DA) of the packet is of 16 bits. The switch drives the packet to respective ports based on this destination address of the packets. Each output port has 16-bit unique port address. If the destination address of the packet matches the port address, then switch drives the packet to the output port, Length of the data is of 16 bits and from 0 to 8191. Length is measured in terms of bytes. Data should be in terms of bytes and can take anything. Frame check sequence contains the security check of the packet. It is calculated over the header and data. The communication on network on chip is carried out by means of router, so for implementing better NOC, the router should be efficiently design. This router supports four parallel connections at the same time. It uses store and forward type of flow control and FSM Controller deterministic routing which improves the performance of router. The switching mechanism used here is packet switching which is generally used on network on chip. In packet switching the data the data transfers in the form of packets between co-operating routers and Independent routing decision is taken. The store and forward flow mechanism is best because it does not reserve channels and thus does not lead to idle physical channels. The arbiter is of rotating priority scheme so that every channel once get chance to transfer its data. In this router both input and output buffering is used so that congestion can be avoided at both sides.

### Features

- Full duplex synchronous serial data transfer
- Variable length of transfer word up to 8192 bytes.
- HEADER is the first data transfer.
- Rx and Tx on both rising or falling
- Fully static synchronous design with one clock domain
- Technology independent VERILOG
- Fully synthesizable.

ROUTER is a Synchronous protocol. The clock signal is provided by the master to provide synchronization. The clock signal controls when data can change and when it is valid for reading. Since ROUTER is synchronous, it has a clock pulse along with the data. RS-232 and other asynchronous protocols do not use a clock pulse, but the data must be timed very accurately.

## OPERATION

The Nine Port Router Design is done by using of the three blocks. The blocks are 16-Bit Register, Router Controller and output block. The router controller is design by using FSM design and the output block consists of four FIFO's combined together. The FIFO's store data packets and when you want to send data that time the data will read from the FIFO's. In this router design has Eight outputs i.e. 16-Bit size and one 16-bit data port. It is used to drive the data into router. we are using the global clock, reset signals, error signal and suspended data signals are the output's of the router. The FSM controller gives the error and SUSPENDED\_DATA\_IN signals. These functions are discussed clearly in below FSM description. The ROUTER can operate with a single master device and with one or more slave devices. If a single slave device is used, the RE (read enable) pin may be fixed to logic low if the slave permits it. Some slaves require the falling edge (HIGH→LOW transition) of the slave select to initiate an action such as the mobile operators, which starts conversion on said transition. With multiple slave devices, an independent RE signal is required from the master for each slave device.

**FIGURES**

## BLOCK DIAGRAM OF 9\_PORT ROUTER

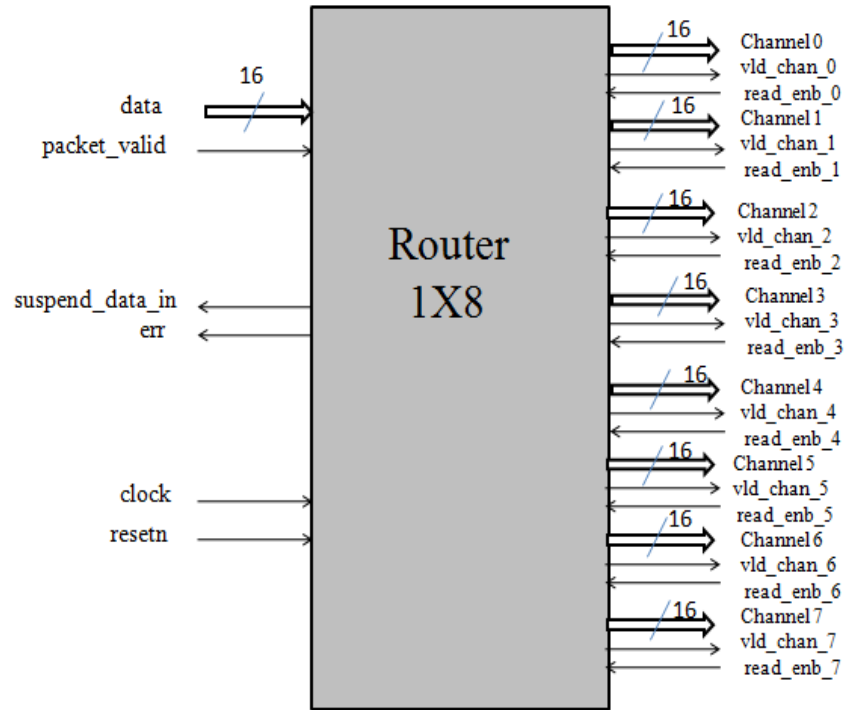

Figure 1: Block Diagram of Nine Port Router

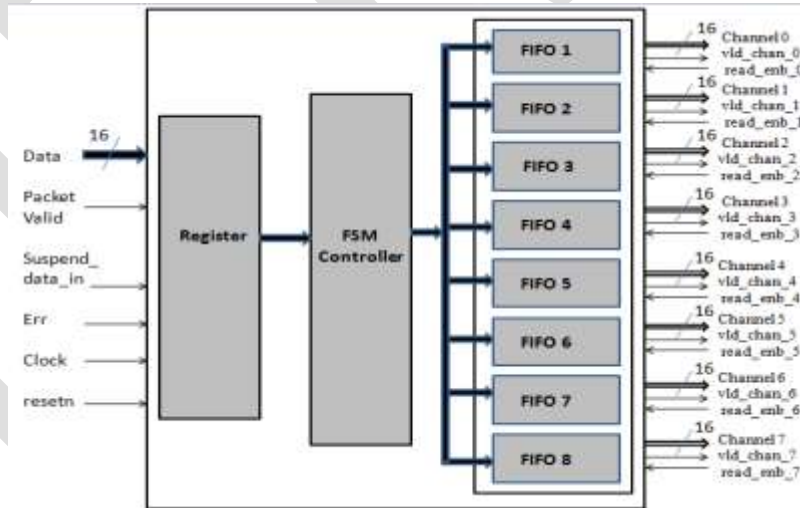

Figure 2: Internal Structure of Nine Port Router

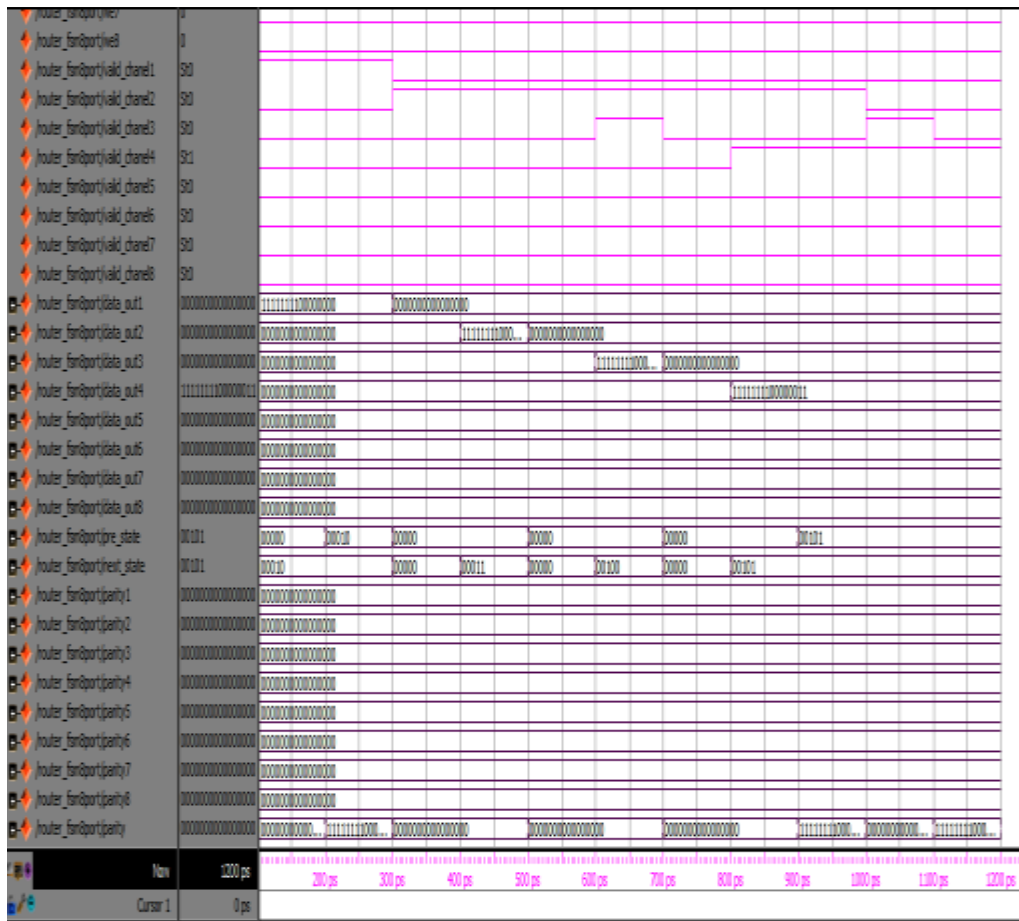

Figure 3: Simulation of FSM Controller

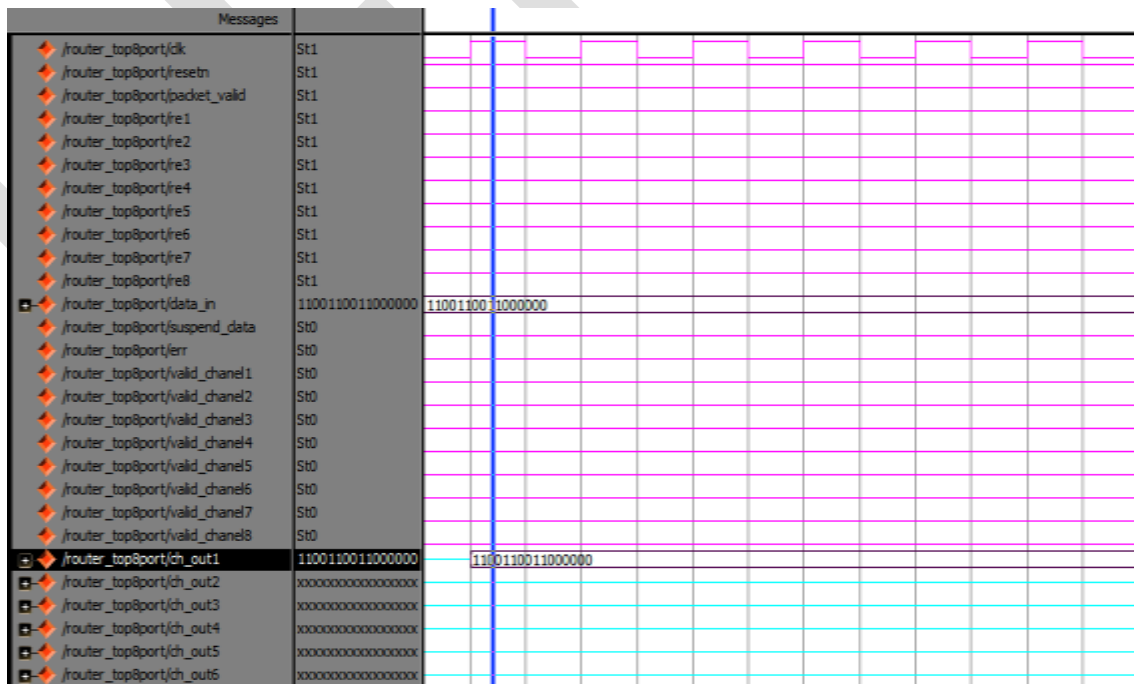

Figure 4: Simulation of Router

## APPLICATIONS

When multiple routers are used in interconnected networks, the routers exchange information about destination addresses, using a dynamic routing protocol. Each router builds up a table listing the preferred routes between any two systems on the interconnected networks. A router has interfaces for different physical types of network connections, (such as copper cables, fiber optic, or wireless transmission). It also contains firmware for different networking protocol standards. Each network interface uses this specialized computer software to enable data packets to be forwarded from one protocol transmission system to another. Routers may also be used to connect two or more logical groups of computer devices known as subnets, each with a different sub-network address. The subnet addresses recorded in the router do not necessarily map directly to the physical interface connections.

Eda Tools And Methodologies

HVL: System VERILOG.

HDL: VERILOG

Device :Sparatan 3e

EDA Tools: MODELSIM,XILINX ISEE

## CONCLUSION

I have designed network ROUTER and I have verified the functionality of the ROUTER with VERILOG which has one input and eight output ports with each 16-bit observed its functional of ROUTER. For design we had verified functionality of router by giving different test cases to different FIFO's based on header address of the packet.

## REFERENCES:

- [1] D. Chiou, "MEMOCODE2011 Hardware/Software CoDesign Contest", <https://ramp.ece.utexas.edu/redmine/Attachments/DesignContest.pdf>
- [2] Blue spec Inc, <http://www.bluespec.com>
- [3] Xilinx, "ML605 Hardware User Guide", [http://www.xilinx.com/support/documentation/boardsand\\_its/ug534.pdf](http://www.xilinx.com/support/documentation/boardsand_its/ug534.pdf)
- [4] Xilinx, "LogiCORE IP Processor Local Bus (PLB) v4.6", [http://www.xilinx.com/support/documentation/ip\\_documentation/plb\\_v46.pdf](http://www.xilinx.com/support/documentation/ip_documentation/plb_v46.pdf)
- [5] "Application Note: Using the Router Interface to Communicate Motorola, ANN91/D Rev. 1, 01/2001.
- [6] Cisco Router OSPF: Design & Implementation Guide, Publisher: McGraw-Hill
- [7] "Nortel Secure Router 4134", Nortel Networks Pvt. Ltd.
- [8] "LRM", IEEE Standard Hardware Description Language Based on the Verilog Hardware Description Language – IEEE STD 1364-1995.
- Books:**
- [9]. Chris Spears SYSTEMVERILOG FOR VERIFICATION, Publisher: Springer.
- [10]. Bhaskar. J, A Verilog HDL Primer,